

GLAUNACH

THE SILENCER HANDBOOK

DIMENSIONING

*A GUIDE TO PARAMETERS AFFECTING
SILENCER SELECTION AND DESIGN*



1. ACOUSTIC DIMENSIONING

1.1 PERMISSIBLE NOISE LEVELS (L_r)

The key factor in designing a silencer installation is the (permissible) **required noise level L_r** , which has to be specified by the customer.



Please note that the design noise level must conform to both user requirements and local legal limits and regulations, in particular such regarding acceptable (occupational) noise exposure.

NOTE: If unsure about applicable requirements and standards, we recommend limiting the sound power level according to the US Occupational Noise Exposure standard OSHA 1910.95.

Personnel Noise Protection Requirements

(excerpted from OSHA 1910.95 and 2003/10/EC)

- When employees are subjected to sound levels exceeding those listed in the table below, feasible administrative or engineering controls shall be utilised. If such controls fail to reduce sound levels to within permissible levels, personal protective equipment shall be provided and used to reduce sound levels to within the prescribed levels.

PERMISSIBLE NOISE EXPOSURES		
Duration per Day [hrs.]	Sound Pressure Levels [dB(A)], slow response ¹⁾	
	OSHA 1910.95 (US)	2003/10/EC (EU)
8	90	87
6	92	
4	95	
3	97	
2	100	
1 ½	102	
1	105	
½	110	
≤ ¼	115	
impulsive noise peaks	140	140

¹⁾ *If the variations in noise level involve maxima at intervals of 1 second or less, it is to be considered continuous.*



If several valves open at the same time, the **cumulative noise effect** needs to be taken into account.

- ❑ When the daily noise exposure is composed of two or more periods of noise exposure of different levels, their combined effect should be considered, rather than the individual effect of each. If the sum of the following fractions

$$C(1)/t(1) + C(2)/t(2) + \dots + C(n)/t(n)$$

C(n): total time of exposure at a specified noise level

t(n): total time of exposure permitted at that level.

exceeds unity, then the mixed exposure should be considered to exceed the limit value.

- ❑ Exposure to impulsive or impact noise should not exceed 140 dB peak sound pressure level.

For more details, please visit <http://www.osha.gov> or <http://eur-lex.europa.eu/en/>

1.2 NOISE LEVEL ADJUSTMENT BY DISTANCE (ΔL_r)

Usually, the sound level is evaluated at a specific distance from the silencer shell. To calculate the noise levels adjusted by the distance, usually the hemispherical sound radiation model is used.

Hemispherical Radiation Model

(Half-Spherical Radiation)

Noise emitted from a silencer installed on a level surface, for instance on a roof, without nearby vertical walls, etc. is in good approximation hemispherically radiated out into the environment. The sound pressure levels decrease with increasing distance from the noise source, i.e. the silencer, according to the following formula:

$$\Delta L_r = 10 \times \log(2 \times \pi \times r^2) \quad [\text{dB}]$$

r: distance [m]

Example Calculation:

The sound pressure level L_{p5m} measured 5 m from the silencer exit is 90 dB.

- Calculate the Sound Power Level L_W ¹⁾
- Calculate the expected sound pressure level L_{p20m} at a distance of 20 m from the outlet

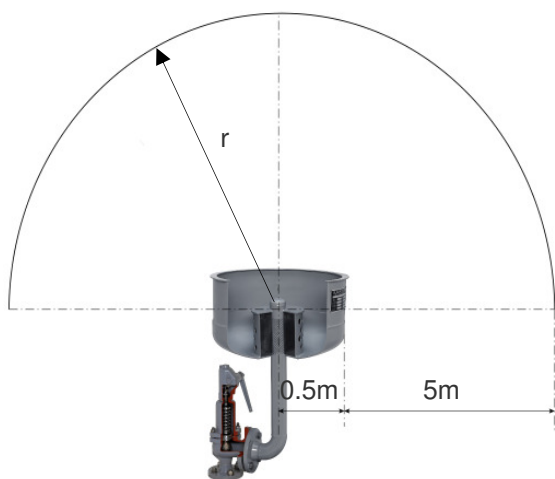

a)

$$\Delta L_r = 10 \times \log(2 \times \pi \times (0.5 + 5)^2)$$

$$\Delta L_r = 22,8 \text{ dB}$$

$$L_W = L_{p5m} + \Delta L_r = 90 + 22,8$$

$$\mathbf{L_W = 112.8 \text{ dB}}$$

b)

$$L_{p20m} = L_W - 10 \times \log(2 \times \pi \times r^2) =$$

$$112,8 - 10 \times \log(2 \times \pi \times (0.5 + 20)^2)$$

$$\mathbf{L_{p20m} = 78.6 \text{ dB}}$$

or, directly

$$L_{p20m} = L_{p5m} - 20 \times \log(r_2/r_1) =$$

$$90 - 20 \times \log((0.5 + 20) / (0.5 + 5))$$

$$\mathbf{L_{p20m} = 78.6 \text{ dB}}$$

IMPORTANT REMARK

The distance from the silencer axis to the silencer shell must also be considered in the noise calculation

¹⁾ assuming a point source

1.3 TRANSMISSION FACTORS (ΔL_{TF})

Sound level adjustment by distance is only valid for *i*) unhindered transmission through air and *ii*) distances up to 25 m from the noise source. If the sound level evaluation point is at a distance greater than 25 m, or if obstacles influence the sound propagation, the following factors should be considered:

ΔL_a	air attenuation [dB]
ΔL_Φ	direction correction [dB]
ΔL_s	screening [dB]
ΔL_v	attenuation by vegetation [dB]
ΔL_{rx}	area factor [dB]
ΔL_b	bottom attenuation [dB] also referred to as <i>ground or terrain attenuation</i>

Several of these factors can only be accurately assessed on-site by a qualified acoustic engineer. The following concentrates on two factors that have almost always to be taken into account, air attenuation ΔL_a and direction correction ΔL_Φ :

Air Attenuation (ΔL_a)

A sound transmitted through air is attenuated in transmission by the air's viscosity and related factors.

The sound absorption properties of air depend primarily on the frequency and the air's temperature and humidity. The following table gives approximated attenuation coefficients for various acoustic frequencies for air with 10°C | 50°F and 70% relative humidity.

f [Hz]	125	250	500	1k	2k	4k	8k
ΔL_a [dB/m]	0.001	0.001	0.002	0.004	0.008	0.021	0.052

Direction Correction (ΔL_Φ)

Silencers direct the sound energy along their main axis, i.e. in vertically installed silencers upwards. This effect can be included in the calculation by adding orientation-dependent correction factors.

The following table lists the sound pressure level increments for different relative angles Φ .

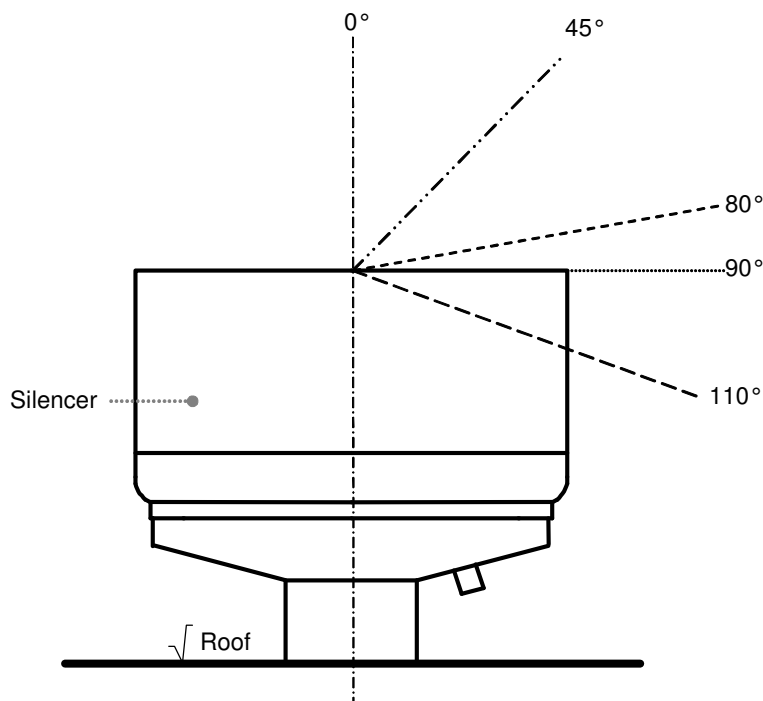

Orientation Angle Φ [°]	110° - 90°	90° - 80°	80° - 45°	0°
Correction Factor [dB] ¹⁾	0	-1	-3	-20

Φ : angle between silencer axis and evaluation point alignment

Given the high noise levels at the silencer outlet and the preferential direction of noise in the direction of the gas plume, the silencer should preferably be directed upwards. Under normal circumstances, the work area (and with it the noise measurement point) is thus below the horizontal axis of the silencer outlet.



Weather hoods and similar devices reflect the sound downwards, even when equipped with a sound-absorbing surface. As this increases the sound level on the ground significantly, we recommend using hoods only if absolutely necessary.

¹⁾ All correction factors are given as attenuation factors, i.e. a negative factor indicates a higher noise level.

1.4 SOUND POWER LEVEL OF VALVES

Valves are a primary source of noise in flow systems. A part of this acoustic energy is transmitted through the valve body, often necessitating an acoustic insulation of the valve itself; the greater part is dissipated through the flowing medium, requiring exhaust silencers.

The following two calculation models can be used for a rough estimation of the sound levels produced by a valve without a silencer:

Valve Noise Estimation acc. to VDI 2713

$$L_{W0} = 17 \times \log(M) + 50 \times \log(T_0) - 15 \text{ [dB]}$$

L_{W0} : sound power levels emitted by the valve [dB]

M : mass flow capacity [t/h]

NOTE: use $M = 10$ t/h for values < 10 t/h

T_0 : Gas temperature at the valve [K]

This formula calculates the **overall sound power**, i.e. the acoustic energy generated by the valve. This is an absolute value, which is not affected by environment or distance.

Valve Noise Estimation acc. to ANSI/API RP 521

$$L_{p30m} = L + 10 \times \log(0.5 \times M \times C^2) \text{ [dB]}$$

L_{p30m} : Sound Pressure Level at 30 m (100 ft) from stack tip [dB]

L : internal sound power level [dB]

M : mass flow capacity [kg/s]

C : speed of sound in the gas at the valve [m/s]

This formula calculates the **sound pressure levels** for an assumed monitoring point 30 m (100 ft) from the valve orifice. This value, while directly related to the actual noise impression and the values measured with a sound meter, can in practice be affected by the surroundings.

COMMENT

These calculations regard only the octave bands from 500 to 8,000 Hz; the resulting A-weighted levels are close to the unweighted dB(Lin) levels, and somewhat higher than the corresponding measured dB(A) values

→ **Both approximations yield values on the safe side.**

Example Calculation:

Calculate the sound power level of a safety valve venting water steam:

mass flow capacity: 100 t/h

upstream temperature: 500 °C

upstream pressure: 50 bar

downstream pressure: 8 bar

□ **acc. to VDI 2713**

$$M = 100 \text{ t/h}$$

$$T_0 = 500^\circ\text{C} + 273.15^\circ\text{C} = 773.15\text{K}$$

$$L_{W0} = 17 \times \log(100) + 50 \times \log(773.15) - 15 \approx \mathbf{163 \text{ dB}}$$

□ **acc. to ANSI/API RP 521**

The internal sound power level L is determined using an L/PR diagram contained in the ANSI/API RP 521 standard. This diagram's input parameter is the upstream/downstream pressure ratio PR , in the present example:

$$PR = 50/8 \approx 6$$

For $PR = 6$, the L/PR diagram yields a internal sound power level

$$L = 60 \text{ dB}$$

With the remaining input parameters

$$M = 100 \text{ t/h} = 27.8 \text{ kg/s}$$

$$C = 664 \text{ m/s}$$

(value taken from "*Properties of Water and Steam*")

the ANSI/API valve noise approximation yields a sound pressure level of

$$L_{p30m} = 60 + 10 \times \log(0.5 \times 27.8 \times 664^2) = 128 \text{ dB}$$

Adjusting for the 30 m distance according to Section 1.2

$$\Delta L_r = 10 \times \log(2 \times \pi \times 30^2) = 38 \text{ dB}$$

$$L_{W0} = L_{p30m} + \Delta L_r = 128 + 38 \approx \mathbf{166 \text{ dB}}$$

yields the estimated sound power level L_{W0} , which is required as input for installation design and dimensioning.

1.5 DETERMINATION OF SILENCER DYNAMIC INSERTION LOSS (DIL)

To determine the necessary dynamic insertion loss (DIL) of any silencer, it is necessary to calculate the permissible sound power level L_W at the silencer outlet. This factor is derived from the permissible noise pressure level at the reference point (L_r , see Section 1.1), the adjustment factor for the distance to the noise source (ΔL_r , see Section 1.2) and the sum of the transmission factors ($\Sigma(\Delta L_{TF}) = \Delta L_a + \Delta L_\phi + \Delta L_{rx} + \Delta L_s + \Delta L_v + \Delta L_b$; see Section 1.3) according to:

$$L_W = L_r + \Delta L_r + \Sigma(\Delta L_{TF}) \quad [\text{dB}]$$

The minimum dynamic insertion loss (DIL) of the silencer to be used can then be calculated by subtracting this value from the sound power level of the valve (L_{W0} , see Section 1.4):

$$\text{DIL} = L_{W0} - L_W \quad [\text{dB}]$$

Dimensioning Example:

A valve installation designed for venting a maximum steam mass flow of 100 t/h (valve inlet temperature 500°C, valve upstream pressure 100 bar) into the atmosphere has to be equipped with a suitable vent silencer to not exceed a sound pressure level of 85 dB(A) at an on-site measurement point 7 m from the exhaust and 50 dB(A) at an off-site measurement point on a nearby hill, 300 m from the silencer and 50 m above the steam outlet level.

The sound power level L_{W0} of the valve can be estimated as ¹⁾:

$$L_{W0} = 17 \times \log(100) + 50 \times \log(273 + 500) - 15 = 163.4 \text{ dB}$$

□ On-Site Reference Point



As the noise source is rather close (< 25 m) to the reference point, it is sufficient to take the distance-dependent noise reduction into account; the transmission factors can be neglected.

¹⁾ Please note the comment in Section 1.4 regarding the estimation of A-weighted noise levels.

The distance effect calculates as

$$\Delta L_r = 10 \times \log(2 \times \pi \times 7^2) = 24.9 \text{ dB}$$

thus yielding a maximum permissible noise power level at the silencer of

$$L_W = 85 + 24.9 = 109.9 \text{ dB}$$

The silencer consequently requires a minimum dynamic insertion loss of

$$\text{DIL} = L_{W0} - L_W = 163.4 - 109.9 = \mathbf{53.5 \text{ dB}}$$

□ Off-Site Reference Point

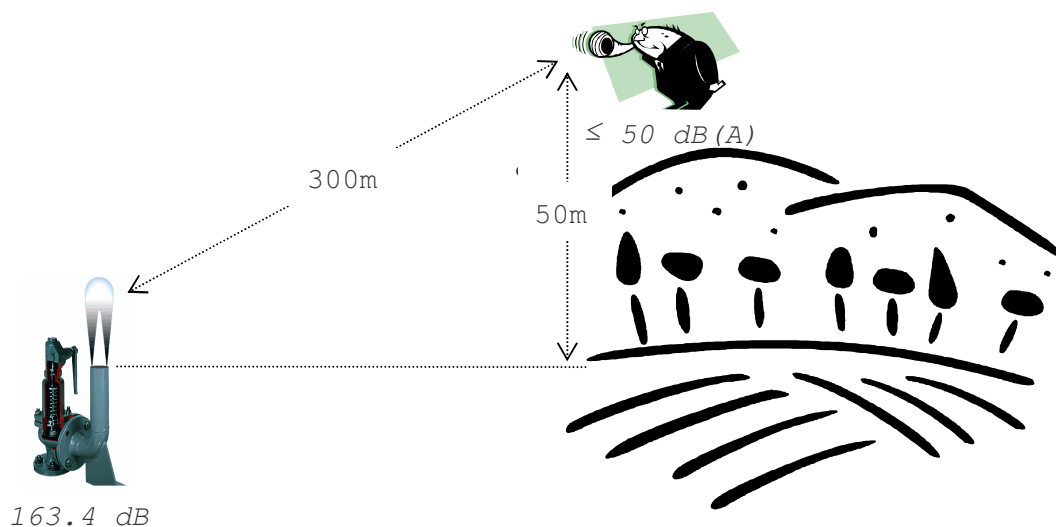

Here, the distance effect amounts to

$$\Delta L_r = 10 \times \log(2 \times \pi \times 300^2) = 57.5 \text{ dB}$$

and the direction correction for the elevated position of the reference point yields

$$\Phi = 80^\circ \rightarrow \Delta L_\Phi = -3 \text{ dB}$$

Taking into account the noise level maximum of a gas flow silenced by a GLAUNACH vent silencer at 2,000 Hz, the air attenuation factor is

$$\Delta L_a = 0.008 \times 300 = 2.4 \text{ dB}$$

yielding a permissible noise power level at the silencer of

$$L_W = 50 + 57.5 + (-3 + 2.4) = 106.9 \text{ dB}$$

and a minimum dynamic insertion loss of

$$\text{DIL} = L_{W0} - L_W = 163.4 - 106.9 = \mathbf{56.5 \text{ dB}}$$

To meet all set noise reduction requirements, the silencer for this problem has to be dimensioned for a DIL-factor of 56.5 dB or better.

1.6 CONDUCTING NOISE CONTROL MEASUREMENTS

acc. to ISO/DIS 11820.2 – Acoustic Measurements on Silencers in-situ

This standard provides a good guideline for how to measure the actual sound pressure levels L_r at the reference points.

The standard specifies *in-situ* measurement procedures of (ducted) silencers, including blow-off silencers (chapter 1.2-b). This includes recommendations for the arrangement of the measuring points for different installation conditions:

- ❑ **Axial measurement:** The standard requires that measuring points be arranged on the silencer axis in front of the blow-off outlet. With blow-off silencers, however, the medium flows out of the silencer outlet at high velocities and possibly high temperatures. Thus, it is not recommended that sound meters be arranged in the gas path at the silencer outlet.
- ❑ **Lateral measurement:** With blow-off silencers, the more common arrangement is to arrange at least one point of reference laterally, i.e. adjacent to or below the silencer opening.

For installations requiring a point of reference over the silencer opening, the lateral reference point can be related to the required in-axis values by applying a direction correction function.

The standard furthermore prescribes the measurement conditions; the table “Corrections for Background Noise” stipulates that the **background sound pressure level** must be more than **3 dB lower** than that of the measured operating sound source during the test. When measuring a silencer, this means that all other noise emissions, including such related to flow noise from pipes and valves, must be accordingly lower.

Legal and customer requirements often demand silencers to achieve extremely low silenced levels, e.g. 85 dB(A) at a lateral position 1 m from the silencer opening. While this is achievable with modern vent silencers, in practice the performance of the silencer is often overlaid with noise emitted from less than ideally installed elements nearby. Site visits reveal that e.g. blow-off pipes between silencer and roof or valve are not insulated, or the valve is outside and radiates noise. Yet, the noise contributions from these sources are often overlooked.



Please note that according ISO/DIS 11820.2, **the control measurement is invalid under such conditions!**

2. THERMAL DIMENSIONING

In addition to the correct material selection for the silencer¹⁾, the thermal expansion in particular of the piping leading to the silencer may have to be taken into account.

The thermal expansion can be derived using the standard formula:

$$\Delta l = l \times \alpha \times \Delta T \times 10^{-6} \quad [\text{m}]$$

¹⁾ see Part V – *Materials & Standards* of THE SILENCER HANDBOOK

thermal expansion coefficient α [$10^{-6} \text{ m}/(\text{m}\cdot\text{K})$], for temperatures up to						
T_{max}	100 °C	200 °C	300 °C	400 °C	500 °C	600 °C
α	11.1	12.1	12.9	13.5	13.9	14.1

Dimensioning Example:

The installation comprises a carbon steel pipe-line leading to the silencer, having a length of 12 m and an operating temperature range of -10 °C to +490 °C.

For temperatures up to 500 °C

$$\alpha = 13.9 \text{ } \mu\text{m}/\text{m}\cdot\text{K}$$

yielding a material expansion of

$$\Delta l = 12 \times 13.9 \times (490 - (-10)) \times 10^{-6} = \mathbf{0.083 \text{ m}}$$

Thus, the installation should provide either an expansion joint or a sliding diffuser ¹⁾ that allows for a vertical movement of at least 83 mm.

3. MECHANICAL DIMENSIONING

3.1 REACTION FORCES

The reaction forces caused by a vertical blow-off can be calculated as follows:

$$R = w_a^2 \times S_a / v_a \text{ [N]}$$

R : reaction force [N]

S_a : outlet surface [m²]

w_a : blow-off velocity of the expanded gas [m/s]

v_a : specific volume of the expanded gas [m³/kg]

Dimensioning Example:

A silencer venting steam with 300 °C into the atmosphere has a mass capacity of 20 kg/s and an open outlet area of 0.7854 m².

In a first step, the specific volume v_a at 300 °C and atmospheric pressure can be taken from a Steam Table ²⁾

$$v_{a(300^\circ\text{C}/1\text{atm})} = 2.63887 \text{ m}^3/\text{kg}$$

¹⁾ please refer to Part III – *Accessories* of THE SILENCER HANDBOOK for available options

²⁾ contained for instance the *VDI Wärmeatlas*

This allows calculating the volumetric gas flow Q_a and subsequently the blow-off velocity w_a

$$Q_a = M \times v_a(300^\circ\text{C}/1\text{atm}) = 52.8 \text{ m}^3/\text{s}$$

$$w_a = Q_a/S_a = 67.2 \text{ m/s}$$

The reaction forces to be taken by the silencer suspension are thus

$$R = w_a^2 \times S_a / v_a = 1345 \text{ N}$$

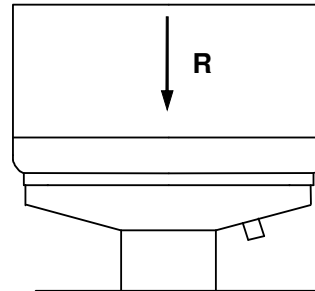

COMMENT

GLAUNACH silencers are specially designed to limit the gas velocities inside. The reaction forces acting during a blow-out event hence are comparatively low and can usually be neglected.

3.2 EXTERNAL FORCES - WIND AND EARTHQUAKES

GLAUNACH silencers are both robust and highly compact in design, allowing transferring even strong wind forces across the shell without any problems.

The support of GLAUNACH silencers, e.g. brackets or legs, are designed to withstand any possible load from wind or earthquakes.

RECOMMENDATION: Support structures that are not part of our shipment should be examined and dimensioned by a qualified structural engineer.

DISCLAIMER

This documentation has been compiled solely for information and assessment purposes, and does not claim comprehensive coverage of how to dimension silencer installations. Users are advised that no liability of any kind related to this document will be accepted by GLAUNACH, including, but not limited to, damage claims due to erroneous or incomplete information.

SYMBOLS

SYMBOL	UNIT	DESCRIPTION
ϕ	$^{\circ}$	orientation angle
α	$10^{-6} \text{m/m}\cdot\text{K}$	thermal expansion coefficient
C	m/s	speed of sound
DIL	dB	dynamic insertion loss
f	Hz	frequency
L	dB	internal noise intensity <i>acc. to API RP521</i>
Δl	m	thermal expansion
ΔL_{ϕ}	dB	direction correction
ΔL_a	dB	air attenuation
ΔL_b	dB	bottom attenuation
L_p	dB	sound pressure level
ΔL_{TF}	dB	sound transmission factors (ΔL_{ϕ} , ΔL_a , ΔL_b , ΔL_{rx} , ΔL_s and ΔL_v)
L_r	dB	required / permissible noise level at the reference point
ΔL_r	dB	noise level reduction by distance
ΔL_{rx}	dB	area factor
ΔL_s	dB	screening factor
ΔL_v	dB	vegetation attenuation
L_w	dB	sound power level
M	kg/s	mass flow capacity (of moving fluid)
P_0	bar(g)	pressure upstream of valve
PR	-	pressure ratio
Q_a	m^3/s	volumetric flow quantity (of moving fluid)
r	m	distance
R	N	reaction force
S_a	m^2	free area at silencer outlet
T_0	$^{\circ}\text{C}$ or K	temperature upstream of valve
v_a	m^3/kg	specific volume
w_a	m/s	blow-off velocity (of expanded gas)